



## G2 Series Application Sheet

Company Type: **Drinking Water Utility**

Market: **Water Supply**

Application Category: **Monitoring**

Model Number: **G2P05N09GMA**

### ADVANTAGES OF USING FLOMEC® METERS

- COST SAVINGS
- SAFETY
- COMPACT SIZE
- ACCURACY
- EASY TO INSTALL

#### APPLICATION:

At the end of the ozone chambers, there are instruments for measuring residual levels of ozone. These ozone analyzers require 1-5 GPM (3.7-18.9 L/min). The sample line runs to a closed waste line, in case there is a high level of ozone. Safety to technicians is a concern when working with ozone. Leaving valves wide open wastes too much water. Flow rate cannot be too low or too high and still

provide accuracy in the analyzer reader. Rotameters had been used but failed due to turbidity levels and the float would stick.

#### PROBLEM:

Opening the pipe to measure sample flow rate could expose technicians to toxic levels of ozone. Leaving valves wide open wastes large volumes of water. If the flow rate is too low or too high, analyzer readings are not accurate.

#### SOLUTION:

Install the FLOMEC G2 meter to monitor sample flow rate. The flow can be adjusted with the throttle valve. The ease of maintenance allows the meter to be checked for build-up and cleaned or be replaced as needed.

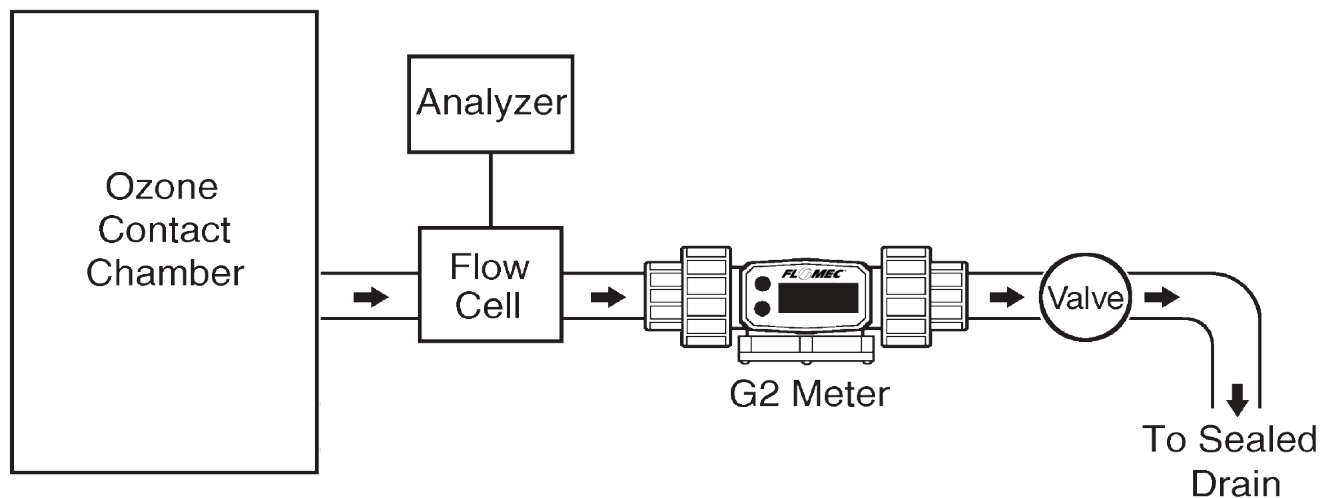

Wichita · Sydney · Mexico City

GREAT PLAINS INDUSTRIES



Great Plains Industries, Inc. / 888-996-3837 / flomec.net

Great Plains Industries, Inc. Australia / +61 2 9540 4433 / flomec.net